

Excitation Control Systems

Contents

<i>Description</i>	<i>Page</i>
Excitation Systems	
Product Description	25-2
Application Description	25-2
Application/Markets Served	25-2
Product Offering	25-3
Features, Benefits and Functions	25-3
Product Selection	25-5
Renewal Parts	25-5
ESC/VR Digital Voltage Regulators	
Product Description	25-6
Application Description	25-6
Features, Benefits and Functions	25-8
Product Specifications	25-8
XMC Automatic Synchronizer	
Product Description	25-9
Application Description	25-9
Operating Modes	25-10
Features, Benefits and Functions	25-10
Product Specifications	25-11
Technical Data and Specifications	25-12



ECS2100 Digital Excitation System



Product Description

Solid-State Voltage Regulators and Excitation Systems

Product Description

Eaton's Cutler-Hammer Type ECS2100, WTA-300B, PRX-400B, and MGR voltage regulators and static exciters are designed for application on medium to large electric utility and industrial generators. Both retrofit and new generation markets are served by this equipment. This product line offers equipment to regulate voltage, control vars or power factor, and provide static excitation and associated limiting and protection features.

Application Description

Excitation control equipment is the equipment providing excitation power, regulation, control and protection for a synchronous machine. The primary function of the equipment is to provide field current. Equally important is the regulation, control and protection aspects of a modern excitation system. These functions are accomplished automatically by appropriate changes in the level of machine excitation.

A modern excitation system not only maintains steady-state response but also maintains continuity of service during a severe power system disturbance or equipment malfunction that would threaten to damage the generating unit or system.

The voltage regulator and excitation system functions to control the output of an ac generator or synchronous motor by varying the machine's field voltage.

Voltage regulation is accomplished by control of thyristor power amplifiers. The excitation may be controlled either manually by a base or dc regulator adjuster or automatically by the ac voltage regulator in response to the generator terminal voltage. The system may be configured to provide var or power factor control instead of terminal voltage regulation.

Application/Markets Served

Upgrade — Retrofits and Replacements

Ideally, the excitation control equipment should do far more than simply regulate voltage under routine operating conditions. Perhaps its most important function is to maintain uninterrupted service during adverse conditions. While modern excitation control systems perform these functions very well, older systems typically do not. Moreover, their operating costs often exceed the cost of owning and operating a modern system.

Cutler-Hammer products offer improved system service, plant availability and plant operating costs by replacing the existing obsolete excitation system with a modern retrofit system.

Cutler-Hammer solid-state controls are designed for retrofit control of single field, multifield and brushless excitation systems, as well as upgrades to completely modern static excitation systems.



Combustion Turbine Installation

November 2003
Vol. 1, Ref. No. [1043]

Type ECS2100

New Generators

Eaton's Cutler-Hammer voltage regulators (VR) and static excitation (SE) systems are compatible with new generation systems as well. The ECS2100 systems are being applied on new generation projects by a number of generator OEMs.

Product Offering

ECS2100 Systems

Our newest family of Cutler-Hammer digital technology excitation systems was introduced in 1999. This fully digital system is suitable for all sizes of utility and industrial generators. Single, dual and supervisory channels of electronic logic are offered. Fiber optics are utilized to eliminate the effects of signal noise inherent in the ac to dc conversion process. The ECS2100 offers a unique patented rectifier bridge current-balancing firing procedure for systems with multiple rectifier bridges that balances the loading of each bridge. The latest in Power System Stabilizer technology is offered. RS-232, RS-485 and Ethernet connections are available for connecting to a Plant DCS.

The ECS2100 has available Event and Analysis and Recording capability that can 1) record up to 2000 alarm events, 2) record and display a single event with displays of eight simultaneous signals while displaying and analyzing both pre-triggered and post-triggered status with up to 9600 data points/channel for each event. In addition, a data logging feature is offered that records up to 12 items in a rolling file for the most recent 1000 values of data.

In addition, the ECS2100 software measures rotor temperature and uses hydrogen pressure, and/or inlet air temperature in order to instantly and continuously adjust excitation to achieve optimal generator output.

The ECS2100 maintains voltage at the set point accuracy of $\pm 0.2\%$.



Drawout Drawer

Features, Benefits and Functions

The following features are typical in excitation systems:

- Unique drawout under load power amplifier drawers for ease of maintenance, as well as continuous operation when redundancy is required.
- Power amplifier's capabilities of providing excitation currents from 20 amperes to 10,000 amperes.
- Automatic and manual modes of regulation.
- Sensitivity ± 0.2 percent of normal voltage from no load to full load.
- Manual control range 30 percent to 125 percent rated load.
- Reactive compensation both droops and rises for paralleling generators.
- Wide range power supplies for reliable control power when ac supply voltages vary from 20 percent to 170 percent of supply voltage.
- Power factor/var control regulation.
- Power System Stabilizer — Integral of Accelerating Power, IEEE PSS2A, mounted integrally within software.
- Optional limiting and protective functions which are designed to follow individual machine stability and thermal limit characteristics typically include:
 - Minimum excitation limiter to prevent excitation reduction that would result in a loss of synchronism of the ac machine with the power system.
 - Maximum excitation limiter to return excitation to a preset limit after brief overexcitation is permitted, such as in field forcing situations.
 - Overexcitation protection to protect the synchronous machine from thermal stress due to overexcitation in both automatic and manual modes.
 - Volts per hertz limiting due to under frequency or overvoltage at constant frequency to avoid excessive heating of the stator and unit transformer windings.
 - Volts per hertz protection for alarm and trip for excessive volts per hertz conditions.
 - Overvoltage protection to phase back control of thyristors upon detection of a set value of generator overvoltage, a condition frequently encountered in hydro generation due to load rejection.
 - Loss of sensing protection to detect loss of voltage regulator which could drive the excitation to ceiling.
 - Field ground detection to protect the generator from a possible ground fault.
 - Adjuster follower to provide smooth transfer from automatic to manual mode and vice versa.
 - Forcing alarm for detecting abnormally high field forcing conditions in both "online" and "offline" operation.



Four Structure Line-up



**WTA-300B/WDR-2000 Potential Source
Static Excitation System**

WTA-300B Systems Using Drawout Trinistat Power Amplifiers

WTA-300B solid-state analog voltage regulators and static exciter/voltage regulators are used on all makes of large utility and industrial generators and motors. The WTA-300B automatic voltage regulators (AVR) are standard equipment on many brushless excitation systems. WTA-300B static exciter/voltage regulator (SE/VR) systems are used for replacement of existing rotating exciters and on new generators worldwide.

The Type WTA-300B features Type M-300 analog regulator logic. Each function consists of a drawout printed circuit module which is mounted in a logic rack assembly within the logic cubicle. The overall design includes individual drawout, front-access, plug-in protective and limiter modules — some of which can be removed under load and replaced with a spare while the faulty module is being repaired. All settings and test points are located on the front of the modules directly inside the hinged door. This ensures ease of making settings and helps in troubleshooting.

WTA-300B systems feature drawout power amplifiers for ease of maintenance. On large generator applications high availability of the unit is a prime consideration. Redundancy of key M-300 modules and the amplifiers is easy with the WTA-300B. When configured for redundancy, a power drawer can be withdrawn under full load for bench testing while the machine continues to operate.



ECS/VR Wall Mounted Unit

ESC/VR Digital Voltage Regulator Systems

Just right for the synchronous generator market. Upgrade to digital with the Eaton's Cutler-Hammer ECS/VR — a voltage regulator for excitation control systems that installs easily and improves system reliability, accuracy and stability.

Increase generating time, dollars and profit. The standardized design, digital platform, and simplified connection scheme combine to significantly reduce the required application engineering and configuration time. Generating efficiency is increased with advanced software that allows the generator to operate at optimum points along its capability curve. The (50 MHz) digital signal processor permits accurate, high-speed computation of advanced control algorithms. Additionally, an integrated 32-bit communication controller allows event recording, data logging, and communications to external control systems for maintenance and analysis functions. All of these features lead to more uptime, which leads your business to more profits.



**MGR Solid-State Regulator for
Single-Field Excitation System**

MGR Analog Static Excitation and Voltage Regulating Systems

The MGR line is offered for static excitation and voltage regulation for small and medium size generators in utility, cogeneration, industrial and hydro applications. The MGR has been designed as a replacement for existing Westinghouse voltage regulators or single field regulators of other manufacturers. It is the recommended replacement for older Westinghouse BJ-30 voltage regulators.

The MGR line is intended for those applications where costs are of concern but limiting and protection functions are important as well. The MGR uses a concept of multifunction limiters and protection features on one printed circuit card. These modules can be added to a system with a separate module containing the voltage regulator logic. The MGR thus permits an economical regulating and excitation system which includes limiting and protection functions for the generator.

Product Selection

Table 25-1 gives application selection for various field current requirements. Contact the factory for quotation.

Table 25-1. System Selection Guide

Equipment Type	Application			Specific Ratings	Features Excitation
	AVR	SEVR	General		
MGR	X	X	<ul style="list-style-type: none"> ■ New generators ■ Existing generators 	Supplies excitation to single field exciters or generator fields up to 1000 amperes	<ul style="list-style-type: none"> ■ Multi-function logic modularity ■ Front access only cubicle ■ Fixed power rectifiers
ESC/VR	X		Retrofit applications	Retrofit for vintage voltage regulators	<ul style="list-style-type: none"> ■ Fully digital system ■ Advanced features
WTA-300B Brushless	X		<ul style="list-style-type: none"> ■ New steam turbine installations > 100 MVA ■ Retrofit applications 	Supplies excitation for generators 100 MVA and up Primary retrofit for WMA brushless systems	<ul style="list-style-type: none"> ■ Modular logic ■ Provisions for redundancy ■ Drawout power rectifiers ■ Drawout ac disconnect
WTA-300B		X	<ul style="list-style-type: none"> ■ New generators ■ Existing generators 	Supplies excitation for generator fields 500 amperes and up	<ul style="list-style-type: none"> ■ Modular logic ■ Provisions for redundancy ■ Drawout power rectifiers ■ Drawout ac disconnect
Mobile Excitation Systems	X	X	Portable standby excitation system	Supplies excitation for systems 6000 amperes and up	<ul style="list-style-type: none"> ■ Supplied in outdoor enclosure ■ Multi-generator design ■ Utilizes ESC2100 system ■ Trailer or skid mounted
ECS2100	X	X	<ul style="list-style-type: none"> ■ New generators ■ Existing generators 	Supplies excitation for systems for all of the above applications	<ul style="list-style-type: none"> ■ Fully digital system ■ Advanced features

① **Renewal Parts**
 AVR — Automatic voltage regulator (supplies excitation to exciter field).
 SEVR — Static exciter voltage regulator (supplies excitation to generator field).

Renewal Parts

Eaton's Cutler-Hammer business offers a complete line of spare parts for current systems, as well as parts for some systems not currently manufactured. Table 25-2 lists systems which do not have spare parts available. For those systems which do not have spare parts available, the recommended system is listed.



Renewal Parts

Table 25-2. Renewal Parts Availability

Product	Parts Not Available	Parts Available	Current Replacement
BJ-30	X	—	MGR, ECS2100
WMA	X	—	PRX-400, ECS2100
WMA BR ②	X	—	WTA-300B, ECS2100
WR-20	X	—	PRX-400, ECS2100
Turbograph	—	X	—
SRA/SRD	X	—	TRA-TRD
TRA/TRD	—	X	—
TRX	—	—	—
PRX-300	—	X	ECS2100
PRX-302	—	X	ECS2100
PRX-400	—	X	ECS2100
MGR	—	X	ECS2100
WTA	—	X	WTA-300B, ECS2100
WTA-300B	—	X	ECS2100
SEVR	—	—	—
XASV	—	X	XMC
XMC	—	X	—
WDR-2000	—	X	ECS2100
ECS2100	—	X	—

② WMA Brushless.
Note: If parts are not available, see current systems for retrofit.

Service Information

Cutler-Hammer excitation control systems are serviced by Cutler-Hammer Engineering Services and Systems (CHESS). Contact your local representative.

ECS/VR Digital Voltage Regulator



ECS/VR Rack Mounted Unit

Product Description

The ECS/VR is a multi microprocessor-based all-digital voltage regulator having a broad range of options for enhanced operational capability. The ECS/VR utilizes the proven technology of the Cutler-Hammer type ECS2100 digital platform with fixed, panel-mounted IGBT power converters. The ECS/VR is a compact voltage regulator/excitation system based on a standardized design. It meets customer needs for applications in the 0 – 20 ampere range. The standardized design, digital platform and simplified connection scheme combine to significantly reduce the required application engineering and configuration time. Units may be rack mounted, panel mounted or wall mounted. Access to all components enhances serviceability. The ECS/VR will provide a modern, reliable voltage regulator with a high level of performance required for the application.

Application Description

The Cutler-Hammer ECS/VR is designed to provide digital voltage regulation, control, protection and monitoring functions for synchronous generators. The ECS/VR uses a digital signal processor for required computational speed of advanced control functions and algorithms and an integrated 32-bit communications controller for implementation of event recording, data logging, and communications to external control systems and to a user-friendly PC interface for maintenance and analysis functions. An optional software program, ccTool, can be used to change settings for the various limiting and protection functions, download new system firmware, and retrieve diagnostics information.

The ECS/VR module system consists of a single Insulated Gate Bipolar Transistor (IGBT) converter with digital pulse-width modulated firing control. Operator control can be provided through a single-cable interconnection to a PanelMate® operator panel, plant DCS system, or through traditional discrete switches, lights and meters. Setup and check-out can be performed via the keypad and the display on the unit.

Power for the ECS/VR can be supplied from:

- The existing 3-phase shaft-driven permanent-magnet generator.
- A reliable alternating current (ac) source, any frequency, single-phase or three-phase.
- A reliable 125 volt direct current (dc) source.
- A reliable 250 Vdc source.

The ECS/VR is intended to be either panel mounted or rack mounted in a control cabinet or wall mounted as needed. This permits retrofitting the unit into an existing enclosure or mounting it into a factory supplied cubicle.

November 2003
Vol. 1, Ref. No. [1047]

Type ESC/VR

Table 25-3. Retrofit Solutions

Is it Time to Retrofit?	Solution
Technical support of vintage equipment is difficult to obtain.	ECS/VR
Replacement parts are very expensive or difficult — if not impossible — to obtain.	ECS/VR
Worn shafts, cams, etc. in motor driven rheostats can be eliminated.	ECS/VR
Buck/boost windings, stabilizing fields, and wire-wound rheostats need to be eliminated.	ECS/VR
Limiters on vintage equipment can no longer be repaired.	ECS/VR
Modern communication capabilities are needed to interface with plant control systems to meet future regulatory requirements.	ECS/VR
Communication capabilities are needed to reduce interface wiring during installation.	ECS/VR
Modeling verification may be needed for future applications.	ECS/VR
You want simple installation, wiring and setup.	ECS/VR

Examples of Westinghouse Retrofit Solutions

- BJ-30
- Silverstat type SRA
- TRA
- TRX-2,3
- WMA (Mag-a-stat)
- WMA-Brushless

Examples of GE Retrofit Solutions

- GFA-4
- GDA Diactor
- SCT/PPT
- Amplidyne

Other potential retrofit opportunities include Electric Machinery, Allis Chalmers, etc.

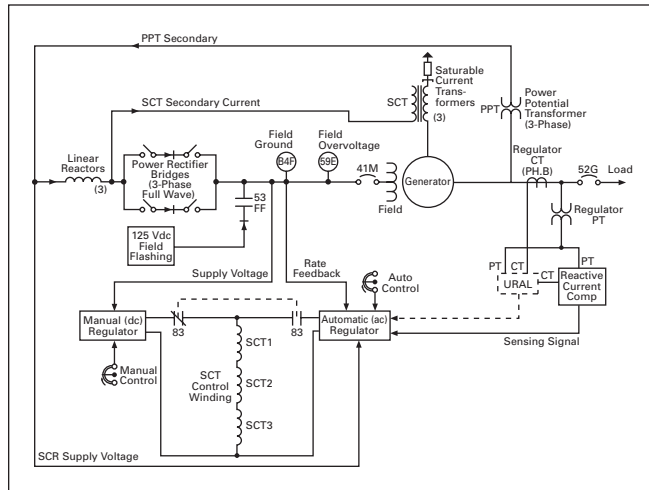

Figure 25-5. Replacement for GE SCT-PPT

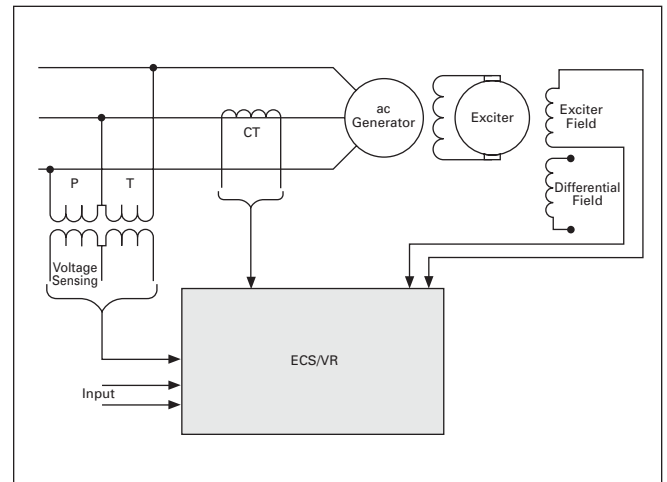

Figure 25-7. ECS/VR Replacement for Brushless Exciter

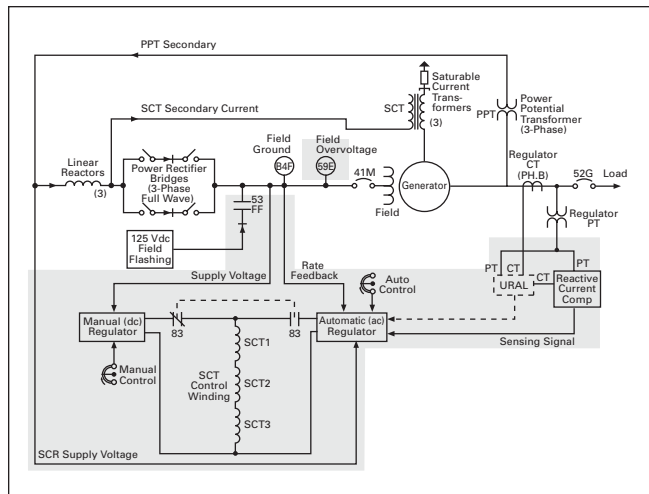

Figure 25-6. Components to be Eliminated for a SCT-PPT Retrofit

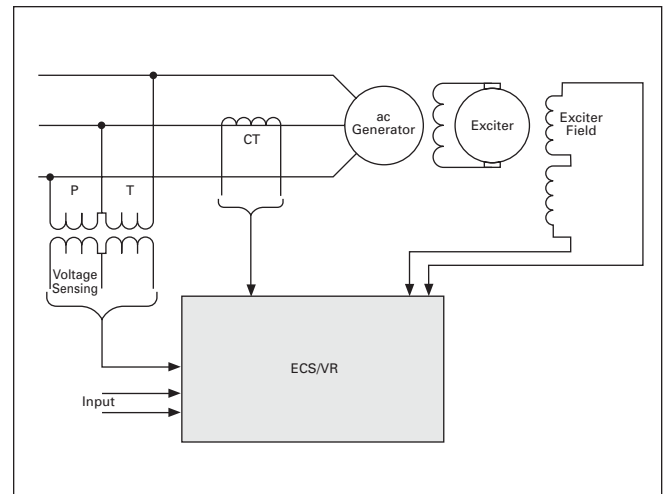

Figure 25-8. ECS/VR Replacement for dc Rotating Exciter

Features, Benefits and Functions

- Rated 20 Adc, 300 Vdc.
- Microprocessor-based design (50 MHz, 32-bit floating point microprocessor).
- Softstart capability.
- Voltage matching.
- Var/PF control.
- Reactive droop or rise compensation.
- Loss of sensing, using one set of PTs only.
- Limiter, field temp and field ground alarms (view status only).
- Trip alarms (view status only).
- Accuracy better than 0.20%.
- HMI for ease of setup.
- Single-phase, three-phase or dc input.
- Wall or rack mountable.
- Maximum excitation limiter/protection.
- Minimum excitation limiter/protection:
 - Steady state
 - Capability curve above limiters with temperature recalibration
- Instantaneous field current limiter/protection.
- Volts/Hz limiter/protection.
- 420 Hz input acceptability.
- LCD graphic backlit display: (320 pix. W x 24 pix. H).
- Password protected.
- Communication: Modbus® TCP; Modbus RTU.

Options

- PSS.
- Field ground detection.
- Alarm logging.
- Data logging.
- Event recording.
- Generator simulator.

Product Specifications

Accuracy

- Voltage regulation .2%.

Ambient Values

- Operating temperature: 50°C.
- Storage temperature range: -20 – 50°C.

Analog Inputs

- Input voltage ± 10 Vdc.
- Impedance:
 - SIM: 200 kilohms
 - TCM: 52 kilohms

Analog Outputs

- Voltage range ± 10 Vdc.
- Maximum current 6 mA.
- Output impedance 100 ohms.

Digital Inputs

- Input voltage 24 to 150 Vdc.
- Impedance:
 - High range 33 kilohms over 51 volts
 - Low range 33 kilohms over 21 volts

Dry Contact Outputs

- Current 10 amperes ac.
- Voltage 250 Vac.

Excitation Output at 50°C

- Continuous current 15/20 Adc.
- Ceiling/forcing (30s max.) 35 Adc.
- Overload (2 minutes max.) 30 Adc.

Excitation Source

- ac input voltage 3-phase 40 – 240 Vac.
- ac input voltage 1-phase 40 – 240 Vac.
- Frequency range 1 – 500 Hz.
- dc input range 50 – 300 Vdc.
- Test voltage 2.5 kV/1 min.

Internal Power Supply

- ac input voltage 1-phase 90 – 130 V.
- dc input voltage 90 – 150 V.
- Maximum power consumption 70 watts.
- Test voltage 1500V/1 minute.

Internal Voltage Source

- Auxiliary voltage source 24 Vdc.
- Output current 3 Adc.

Measurement Inputs

- Generator voltage 130 V (max.).
- Generator current (1fl or 2fl) 5 A.
- Power consumption 8 VA.
- Line voltage 1-phase 130 V (max.).
- Frequency range 40 – 100 Hz.
- Test voltage (High Pot.) 150 Vac.

Mechanical Data

- Enclosure NEMA® 1.
- Exterior finish ANSI 61.

Serial Interface

- Ethernet TCP/IP RS-485.
- Remote PanelMate RS-485.
- ccTool software RS-232.
- Modem RS-232.

November 2003
Vol. 1, Ref. No. [1049]

Type XMC

XMC Automatic Synchronizer

Product Description

Eaton's Cutler-Hammer Type XMC microprocessor-based automatic synchronizer is designed to eliminate synchronization risk by relieving operating personnel of the task of properly connecting generators to the power system bus. The XMC family of automatic synchronizers provides a unique, microprocessor-based system delivering increased reliability and flexibility in a single package. A simplified block diagram illustrates this function.

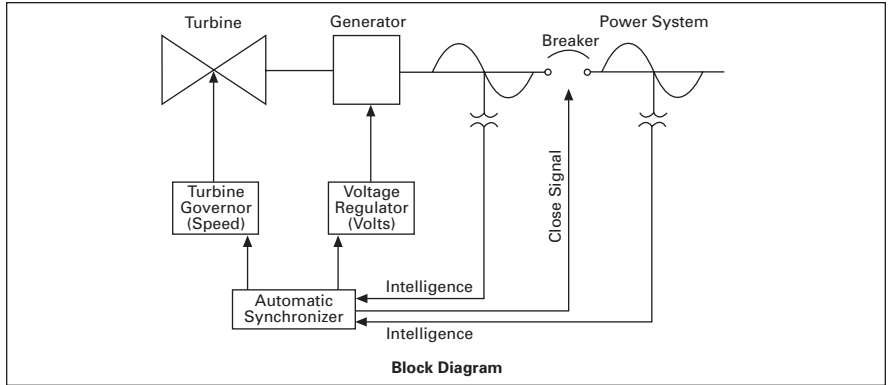

Figure 25-9. Block Diagram

Application Description

Models

The XMC family of automatic synchronizers comes in three basic models all supplied in the same size enclosure, mounting and drawout design.

Model Description

XM XM provides automatic synchronizing, plus voltage and speed acceptance.

Note: The operator makes the voltage and speed adjustments.

XMC Provides complete automatic synchronizing, voltage and speed acceptance, voltage and speed matching for one breaker closing time.

XMC-4 Provides complete automatic synchronizing, voltage and speed acceptance, voltage and speed matching with up to four breakers with four different closing times.

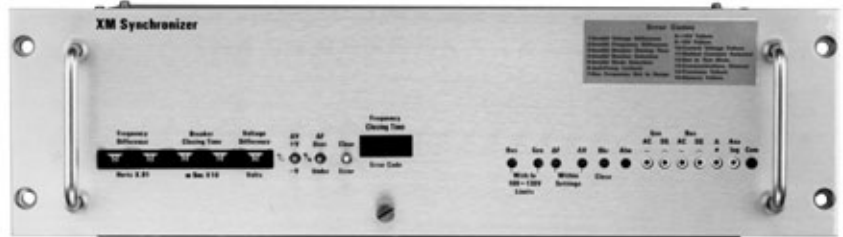

Model XM



Model XMC

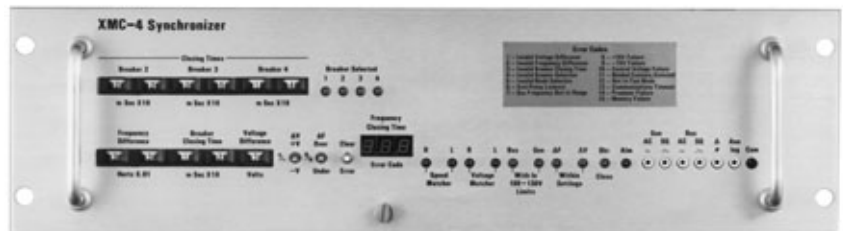

Model XMC-4

Operating Modes

The XMC family of automatic synchronizers may operate in the following different modes. Mode selection is accomplished by an external control switch (not included in synchronizer).

Automatic

The automatic synchronizer makes voltage and speed adjustments and issues the command to close the generator breaker the first time proper conditions have been met.

Supervised Operator

This operating mode allows the operator to control generator speed and voltage, and then close the breaker under proper conditions. If the operator fails to close the breaker within the permissive window, the breaker close command is not issued. The operator must then reset the breaker control switch, and make another attempt to close the breaker within the permissive window.

Automatic Standby

The automatic standby mode allows the operator to inspect the performance of the synchronizer and to see when the close command would have been issued in the automatic mode. The synchronizer makes the proper voltage and speed adjustments and when the synchronizing conditions are met, closes an auxiliary relay (advance angle relay) rather than the breaker close relay. The synchronizer will operate the advance angle relay at the proper advance angle once every scope period. Exiting the automatic standby mode and returning to the automatic mode will result in the breaker close command being issued.

Dead Bus

If an automatic synchronizer has been implemented into the synchronizing scheme, it will not allow the generator breaker to close into a de-energized bus. In this mode the operator can elect to close into a dead bus. Dead bus voltage is defined as a voltage less than 15 volts. The generator voltage must be between 100 – 130 volts. Bus voltage must remain below 15 volts for 5 seconds.

Bus-to-Bus (Optional)

This mode of operation allows the synchronizer to close the tie breaker that will connect two separate bus systems together. If the two systems are within selected allowable limits for a selected time, the synchronizer will issue the closing command to the tie breaker.

Features, Benefits and Functions

Proportional Control

Proportional control eliminates overshoot or hunt by providing variable pulse times that decrease in duration as generator and power system voltage and speed coverage.

Voltage Acceptance

Voltage control will not begin until the generator voltage and bus voltage are within the range of 100 volts and 130 volts.

Voltage Matching (Δv)

Thumb wheels allow adjustable settings for generator to bus voltage difference in a range from 1 to 5 volts in one (1) volt increments.

Voltage Permissive Synchronizing

A three-position switch allows synchronization with the generator voltage greater than bus voltage, less than bus voltage or absolute voltage sensing.

Voltage Matching Control

Chassis selectable voltage control algorithms allow the user to fine tune the synchronizer to the characteristics of the system.

Speed Acceptance

Speed control will not begin until the generator frequency and the power system frequency are within a fixed range of $\pm 10\%$ of synchronous speed.

Speed Matching (Δf)

Thumb wheels allow adjustable settings for generator to bus frequency difference in a range from 0.01 Hz to 0.5 Hz in steps of 0.01 Hz.

Speed Permissive Synchronizing

A three-position switch allows synchronization if the generator frequency is greater than bus frequency, less than bus frequency or for either condition.

Speed Matching Control

Chassis selectable speed control algorithms allow the user to fine tune the synchronizer to the characteristics of the system.

Speed Correction Pulse

Should the incoming generator stabilize at the exact speed of the bus but be out of phase, then a kicker pulse will be given to the raise or lower speed relay (depends on which speed permissive selection was made).

Breaker Closing Time

Thumb wheels allow adjustable settings for breaker closing times in a range from 40 to 500 milliseconds in increments of 10 milliseconds (XMC-4 provides up to four different breaker closing time settings).

Breaker Closing Time Indication

Breaker closing time is measured and displayed on the digital display.

Breaker Antipump Lockout

A failure of the generator breaker to remain closed for 1 second after given a closure command will result in the synchronizer locking out to prevent repetitive closure attempts.

Digital Display

The front panel digital display provides an actual readout for incoming generator frequency, breaker closing time at each synchronization and error code indication.

Self-Diagnostics

The internal circuitry interrogates operation of the ac supply, internal dc power supply, memory failure, processor failure, and welded contacts.

Error Code Indication

Error conditions are displayed in the digital display. Error conditions indicated include setup errors, fatal (lockout) operational errors and auto-resettable errors.

Analog Protective Circuit

The digital system is backed up by an analog protective circuit which will prevent breaker closure outside a 30 degree advance angle or if the frequency difference is greater than 0.5 Hz (i.e., synchroscope period greater than 2 seconds).

Dead Bus Closure

The operator can elect to close into a dead bus. Dead bus voltage is defined as a voltage less than 15 volts. The generator voltage must be between 100 – 130 volts. Bus voltage must remain below 15 volts for 5 seconds.

Test Points

Front panel test jacks are available to monitor internal circuit waveforms which include analog backup angle, generator to bus phase difference, generator and bus square wave voltages, and dc levels proportional to generator and bus rms voltage.

50/60 Hertz

The XMC synchronizers will operate on both 50 Hz and 60 Hz systems.

Drawout Design

The XMC synchronizers feature a 19-inch (482.6 mm) rack mount drawout design.

Surge Withstand

The XMC synchronizer has been designed to meet the requirements of ANSI C37.90a.

November 2003
Vol. 1, Ref. No. [1051]

Type XMC

Product Specifications

- Ambient temperature:
 - Maximum 50°C
 - Minimum -20°C
- Weight 25 pounds (11.4 kg).
- Size 19 inches W x 5.25 inches H x 14.75 inches D (482.6 mm W x 133.4 H mm x 374.7 D mm).
- Accuracy ± 3 degrees.
- ac Power supply:
 - 20/240 Vac
 - 25 VA Burden
 - 47 Hz – 63 Hz
- Input signals:
 - Generator voltage 120 Vac 50/60 Hz 0.5 VA burden
 - Bus system voltage 120 Vac 50/60 Hz 0.5 VA burden
- Output relay contact rating:
 - Make and carry 10 A, 120 Vac
 - Interrupt inducting load 1.0 A, 125 Vac
 - Open contact withstand 1200 Vac
- Operator settings:
 - Differential voltage 1 to 5 volts, 1 volt increment
 - Differential frequency 0.01 to .5 Hz, .01 Hz increment
 - Breaker closing times 40 to 500 milliseconds, 10 ms increment

Purpose

The following is a typical specification that may be used for specifying the XMC automatic synchronizer.

General

Automatic synchronizing equipment shall be furnished to close the generator breakers during synchronizing of the generating units. The equipment shall include an automatic synchronizer, a speed matcher, voltage acceptor, and voltage matching equipment to automatically adjust the frequency and voltage of the incoming generator to match that of the bus. The equipment shall close the breaker when the running and incoming voltages are in accurate synchronism and when the voltage and frequency differences of the two sources are within preset limits as defined below.

In addition, for synchronizing a generator breaker, the equipment shall provide smooth anti-hunt automatic control of the generator speed and voltage level without over-travel. The control of the generator voltage will be by a owner-furnished, motor-operated, voltage-adjusting rheostat on the excitation equipment. The control of generator speed will be by a owner-furnished, motor-operated governor speed changer. The automatic synchronizer shall start up when the synchronizing switch is in "automatic" position, and potential selection has occurred.

Automatic Synchronizing Equipment

The automatic synchronizing equipment shall function to permit closing of selected generator breakers under the following permissive conditions: voltage matched, and frequency difference within preset tolerance, closing initiated before zero-phase difference by lead time equal to breaker closing time.

Synchronizer Features

1. The synchronizer is applicable for 60 Hz systems. The burden imposed on the incoming generator and on the running bus PT transformers with 120-volt secondaries is 0.5 volt amperes. Power supply burden is 25-volt amperes.
2. The synchronizer is designed to close the breaker within plus and minus 3 degrees of phase coincidence. The maximum allowable advance angle is 30 degrees. The operating temperature range is -20 to +50 degrees centigrade.

3. The rating of the output relay contacts is 5 amperes continuous with an interrupting rating of 1 ampere resistive at 125 volts direct current.
4. The selectable breaker closing time by the synchronizers thumb switch is from 40 to 500 milliseconds in increments of 10 milliseconds.
5. The selectable voltage difference on the synchronizer thumbwheel switch is 1, 2, 3, 4 and 5 volts. The tolerances on these settings is 0.5 volts.

A three-position voltage difference polarity switch gives choice of synchronizing only with generator voltage greater than bus system voltage, less than, or either.

The synchronizer has a fixed undervoltage lockout at 100 volts and an overvoltage lockout at 130 volts for both incoming generator and running bus system.

6. The selectable frequency difference range on the synchronizer thumbwheel switch is from 0.01 to 0.5 Hz in steps of 0.1 Hz.

A three-position frequency difference polarity switch gives choice of synchronizing only with incoming generator frequency greater than bus system frequency, less than, or either.

The synchronizer will lockout if the bus system frequency is outside a plus and minus 2 Hz difference from its normal frequency.

It also has a fixed under frequency lockout at -10 percent of nominal frequency and an over frequency lockout at +10 percent of nominal frequency for both incoming generator and running bus system.

7. A built-in analog protective circuit will only allow synchronizing when the advance angle is within 30 degrees of phase coincidence and when the frequency difference is less than 0.5 Hz.

Type XMC — Technical Data and Specifications

- 8. A 16-position selector switch allows choice of different pulse and wait voltage control algorithms.

The voltage control system is only operable in the 100- to 130-voltage range.

- 9. A 16-position selector switch allows choice of different pulse and wait speed control algorithms.

The speed control system is only operable when within plus and minus 10 percent of the nominal system frequency.

When the incoming generator stabilizes at the exact speed of the bus system (hung scope) for one second, the synchronizer will issue a speed correction signal.

- 10. An anti-pump feature allows only one closure attempt for a single close operation.
- 11. Seven test jacks on front of the synchronizer measure generator and bus system rectified voltages

and squared voltages, phase difference voltage, and analog protective circuit voltage.

- 12. The three-digit display window will give indication of incoming generator frequency until the breaker close command is issued. Then it indicates the measured breaker closing time. If any alarm occurs, the window displays an alarm error code.

When in the bus-to-bus system synchronizing mode, the display is of the phase angle difference between the two systems. When the tie breaker does close, the breaker closing time is displayed.

- 13. When the synchronizer is in the dead bus parameters mode, a close command is issued if the incoming generator voltage is with the 100- to 130-voltage range and the bus system voltage is measured as being below 15 volts for 5 seconds.

- 14. The synchronizer shall be Cutler-Hammer Type XMC or equal. The automatic synchronizer shall be complete with solid-state automatic synchronizer module, voltage-acceptor, speed-matching, and voltage-matching modules and shall include contact outputs.

- 15. The synchronizer package assembly shall be suitable for 19-inch (482.6 mm) rack panel mounting on a switchboard panel of 11-gauge steel. The synchronizer shall be of drawout construction.

- 16. The synchronizer shall be designed to meet the requirements of ANSI C37.90a surge withstand.

Modbus is a registered trademark of Modicon, a division of Schneider Electric Industries SA. NEMA is the registered trademark and service mark of the National Electrical Manufacturers Association.

Technical Data and Specifications

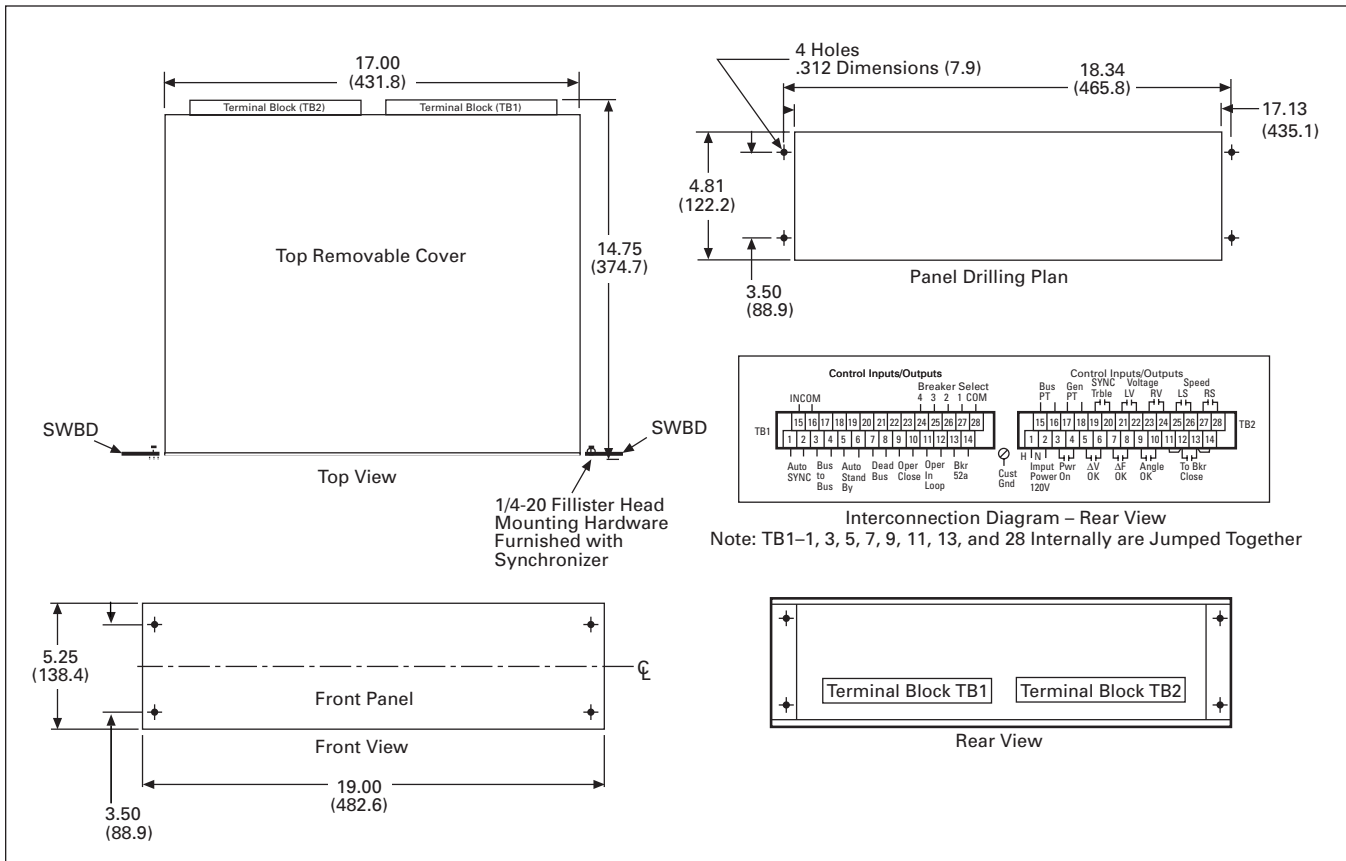

Figure 25-10. Typical Outline and Drilling Plan — Dimensions in Inches (mm)