

FUNCTIONAL DESCRIPTION

The basic BE3-25A monitors the oncoming generator and bus voltages and permits synchronizing the generator to an energized station bus or another generator when the following predetermined conditions are satisfied:

- A) The slip frequency is ± 0.1 hertz or less.
- B) The phase angle differential is equal to or less than the selected setting ranging from $\pm 5^\circ$ to $\pm 20^\circ$ adjustable in five degree increments.
- C) The generator and bus voltage differential is less than the selected voltage difference setting continuously adjustable ranging from $\pm 5\%$ to $\pm 15\%$ of the bus voltage.

When a jumper is connected across the 0.75 second time delay terminals of the unit, the automatic synchronizer will synchronize the generator when the generator voltage within the selected voltage difference setting and the measured phase angle and slip frequency are less than the following:

Phase Angle Setting	Max. Slip Frequency
$\pm 5^\circ$	$\pm .037\text{Hz}$
$\pm 10^\circ$	$\pm .074\text{Hz}$
$\pm 15^\circ$	$\pm 0.1 \text{ Hz}$
$\pm 20^\circ$	$\pm 0.1 \text{ Hz}$

When the phase angle, frequency, and voltage are within predetermined limits, the automatic synchronizer energizes the isolated synchronizing output relay initiating generator circuit breaker closure, illuminates the sync LED and immediately resets the frequency and phase angle correction signals. The correction signal can be reset when desired by installing a normally open contact between the reset terminals of the synchronizer. Closure of this contact, together with the energization of the synchronizing output relay for breaker closure, will reset the correction output signals.

FREQUENCY MATCHING: Five frequency matching options are available. The synchronizer will provide correction signals when the phase angle and/or slip frequency exceed the settings. These signals cause the governor to increase or decrease the prime mover's speed.

Four frequency options are available:

TYPE A: Provides a low voltage signal to AMBAC International governors, type CU673C.

TYPE B: Provides a proportional bipolar signal to Barber Colman governors, types DYN1, ILS.

TYPE C: Provides contact outputs for motor operated control operation.

TYPE W: Provides a proportional bipolar signal to Woodward governors, types 1712-1724, 2301, 2301A.

The correction signals are proportional to the magnitude of the slip frequency and phase angle, and continue until the conditions for breaker closure are satisfied. Frequency correction signals are at maximum until the generator frequency is within ± 3 hertz of the station bus frequency, then becomes proportional.

VOLTAGE MATCHING: If optional voltage matching is specified, the synchronizer provides correction signals to the generator regulator when the difference between the generator and bus voltages exceeds the predetermined front panel setting.

Two types of voltage correction signals are optionally available:

OPTION 1: Bipolar correction signal (proportional to the magnitude of monitored voltage difference) for use with summing point input Basler voltage regulator types AVC63-12, AVC125-10, DECS, SSR, SR, KR, and XR; and exciter regulators, Types SSE and SER-CB.

OPTION 2: Raise/lower output contacts provide control signals for a motor operated control.

The value of allowable difference for breaker closure is selectable in 1% increments over the range of $\pm 1\%$ to $\pm 5\%$ by adjusting a printed circuit board mounted switch accessible from the front panel. The corrective signals are continuous until conditions for breaker closure are satisfied.

DEAD BUS: Selection of the dead bus feature enables the BE3-25A to close the circuit breaker connecting the oncoming generator to a de-energized bus. The dead bus voltage is continuously adjustable from 10 to 50 Vac (at 120V tap) by a printed circuit board mounted potentiometer accessible from the front panel. The dead bus option is inhibited from operation by removal of the jumper connected across the dead bus terminals.

SPECIFICATIONS

Electrical:

POWER SUPPLY: Designed to receive its input through a jumper connection from either the generator voltage input terminals or bus voltage input terminals. A front panel light emitting diode (LED) illuminates to indicate the power supply is providing normal operation voltages to the synchronizer. A decrease of the input voltage to the power supply below 80 Vac causes the synchronizer to remove all correction signals to the controlled electronic governor and voltage regulator. Burden is 11 VA.

Power Supply	
Max. Operating Range	Frequency
80-140 Vac 180-264	50 Hz
87-153 Vac 167-304	60 Hz

SENSING INPUT: The generator and bus voltage input sensing circuits impose a maximum of 2 VA burden on the potential transformers at nominal voltage. The generator and bus inputs are rated for 150% of nominal input for a time period of two seconds. Table 1 defines the sensing input range for the monitored generator and bus voltages.

Sensing Input Range			Burden
	120 Vac	240 Vac	
50 Hz	80-140 Vac	180-264 Vac	2 VA
60 Hz	87-153 Vac	167-304 Vac	

TABLE 1

RATED FREQUENCY: 50/60 Hz

BREAKER CLOSURE: Contact rated for 4 amps at 120 Vac or 28 Vdc (resistive); 4 amps at 220 Vac (resistive).

FREQUENCY/PHASE ANGLE MATCHING CORRECTION SIGNALS:

Raise/Lower Contact: Continuous contact closure signal. Contacts rated: 2 amps at 240 Vac (resistive), or 28 Vdc 2 amps (resistive), 1/3 HP at 120 Vac.

Summing Point: ± 4 Vdc (maximum) bipolar signal compatible with Barber Colman electronic summing point governors. American Bosch electronic governors $+ 5 \pm 4$ Vdc. Woodward electronic governors ± 6 Vdc (maximum) bipolar. All outputs are isolated.

VOLTAGE MATCHING:

Raise/lower Contact: Continuous contact closure signal. Contacts rated: 2 amps at 240 Vac (resistive) or 28 Vdc 2 amps (resistive) 1/3 HP at 120 Vac.

Summing Point: Bipolar signal compatible with Basler Electric voltage regulator types AVC63-12, AVC125-10, DECS, SSR, SR, KR, and XR; and exciter regulators types SSE and SER-CB.

BREAKER CLOSING ANGLE: $\pm 5^\circ$ to $\pm 20^\circ$ range adjustable in 5° increments.

VOLTAGE ACCEPTANCE:

Basic Synchronizer: $\pm 5\%$ to $\pm 15\%$ of the bus voltage front panel accessible continuous adjustment.

Optional Voltage Matching Differential: 1 - 5% adjustable in 1% increments. Front panel accessible switch.

DEAD BUS:

Dead bus voltage level is continuously adjustable over the range of 10 to 50 Vac $\pm 5\%$ (at the 120 Vac tap) by a front panel accessible potentiometer.

Physical:

OPERATING TEMPERATURE: -40°C (-40°F) to 70°C (158°F).

STORAGE TEMPERATURE: -65°C (-85°F) to 85°C (185°F).

SHOCK: Withstand 15Gs in each of three mutually perpendicular axes.

FINISH: Dark gray, textured, baked enamel.

WEIGHT: 4 lbs. (1.82kg).

VIBRATION: Tested and withstands the following:

Frequency	Level
5-18 Hz	0.06 inch double amplitude
18-30 Hz	1G
30-48 Hz	0.02 inch double amplitude
48-70 Hz	2.5 Gs

INTERCONNECTIONS

Output Breaker (Sync) Connection

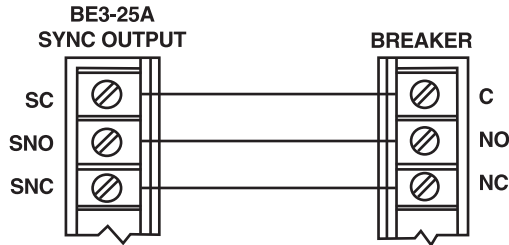
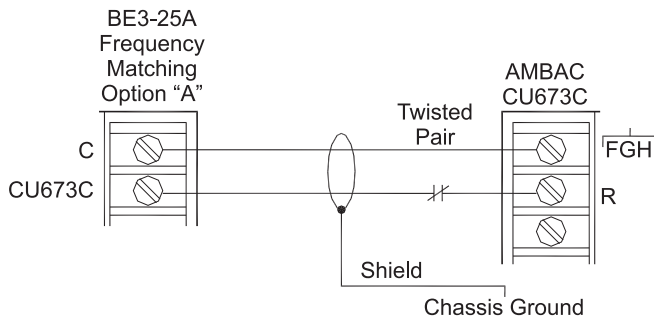

Figure 1 - Sync Output Connection

Summing Point Governor



NOTE: A normally-closed contact is required between the synchronizer and pin "R" which will open after sync or when power is removed from the BE3-25A.

Figure 2 - Ambac International CU673C Interconnection

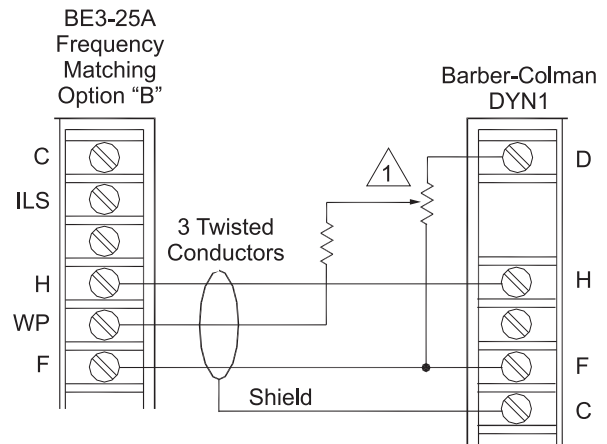

1 See governor manual for resistor values.

Figure 3 - Barber-Colman DYN1 Interconnection

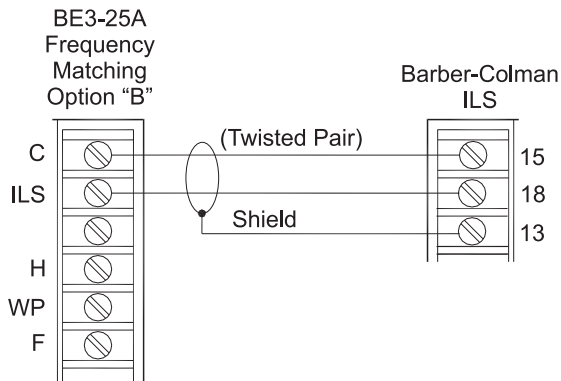

Figure 4 - Barber-Colman ILS Interconnection

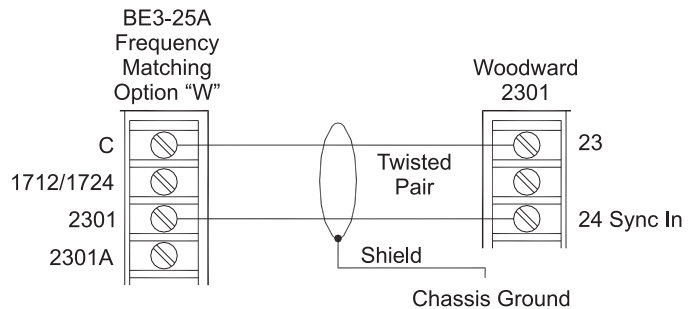

Figure 5 - Woodward 2301 Interconnection

INTERCONNECTIONS, continued

Summing Point Governor (continued)

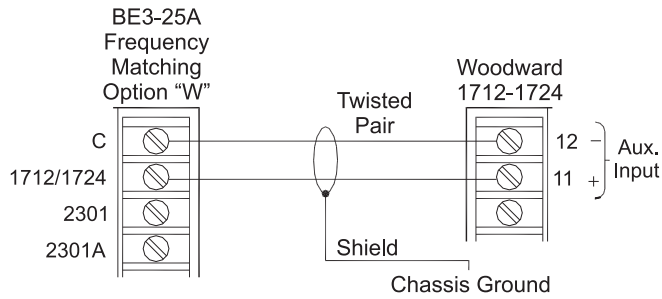
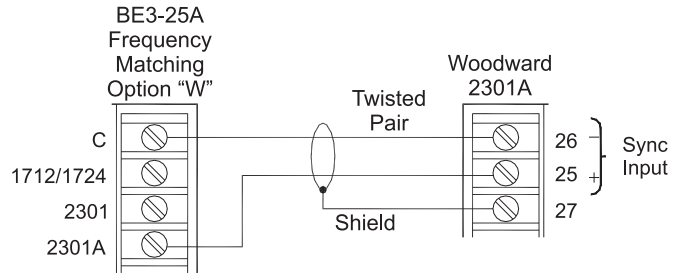

Figure 6 - Woodward 1712-1724 Interconnection



NOTE: When the possibility exists that the shield is connected to chassis ground or earth ground, do not connect the shield to terminal 27. Ground the shield to the chassis at one point only.

Figure 7 - Woodward 2301 A Interconnection

Raise/Lower Contacts — Voltage Regulator/Governor

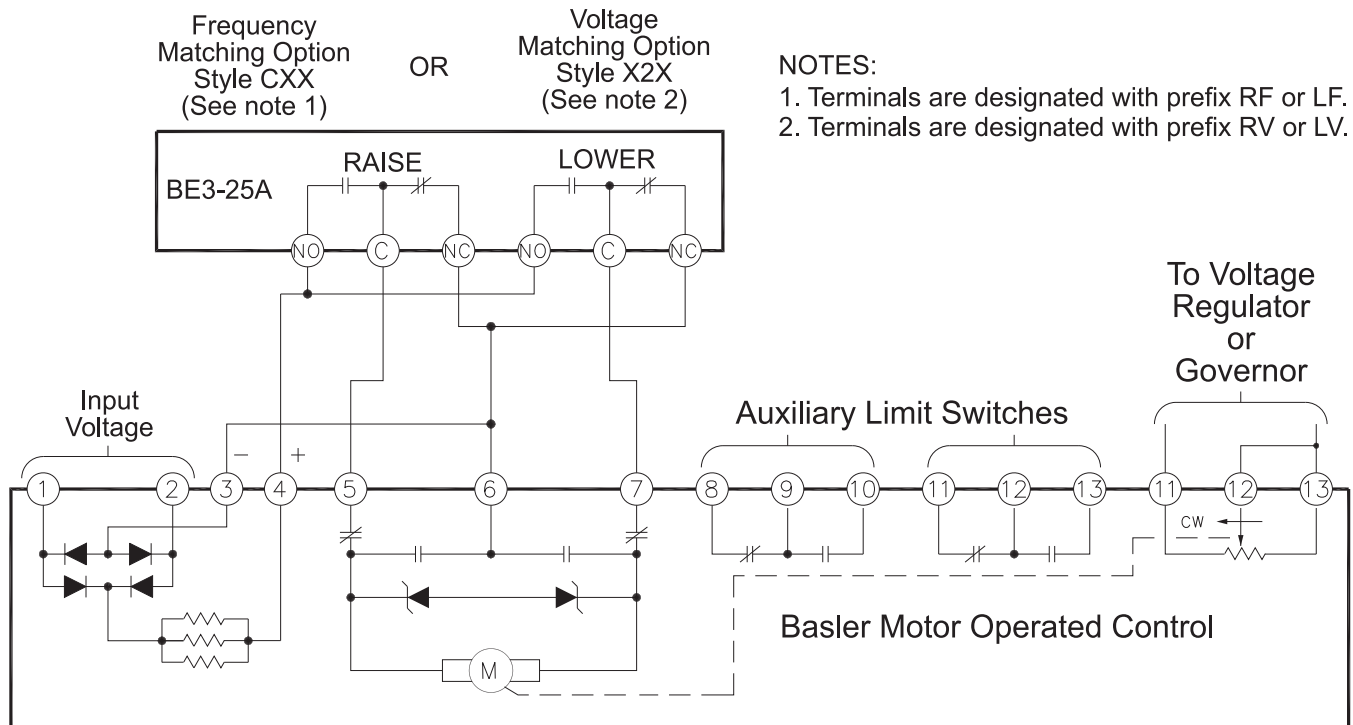

NOTES:

1. Terminals are designated with prefix RF or LF.
2. Terminals are designated with prefix RV or LV.

Figure 8 - Raise/Lower Contact Interconnection

INTERCONNECTIONS, continued

Voltage Regulator — Summing Point

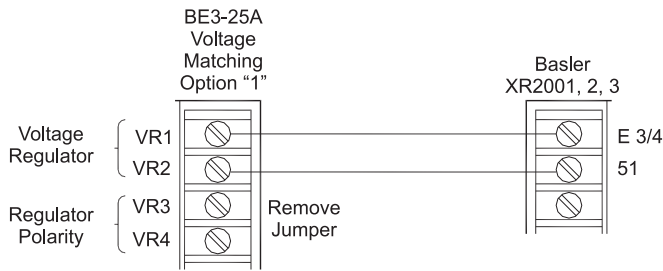

Figure 9 - Basler XR2001, XR2002, XR2003 Interconnection

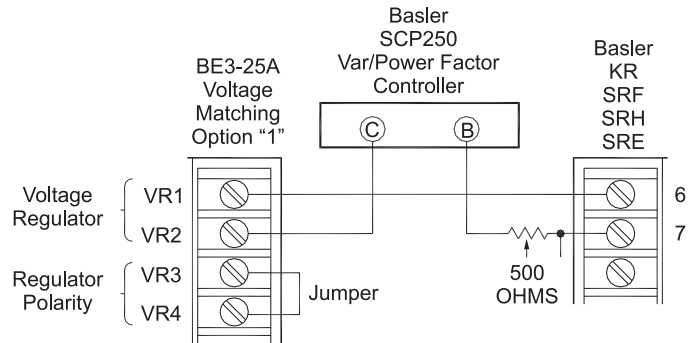

Figure 10 - Basler KR, SRF, SRH, SRE Interconnection

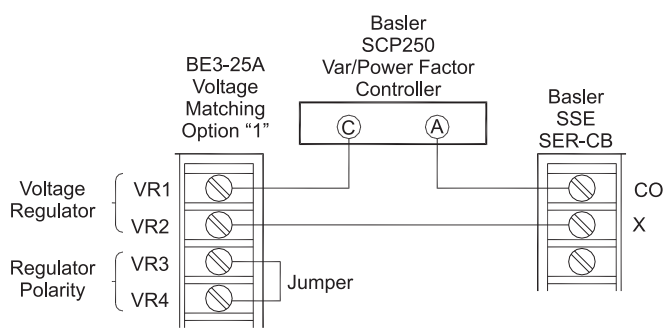

Figure 11 - Basler SSE, SER-CB Interconnection

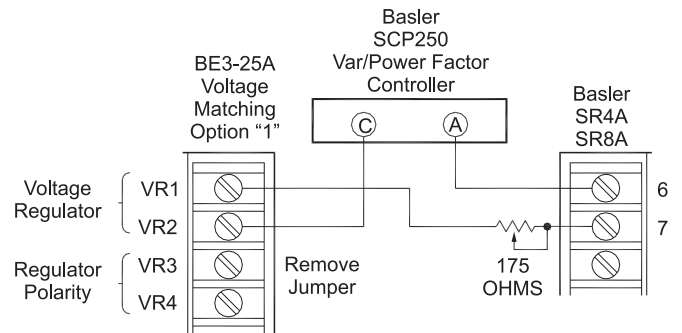

Figure 12 - Basler SRA Interconnection

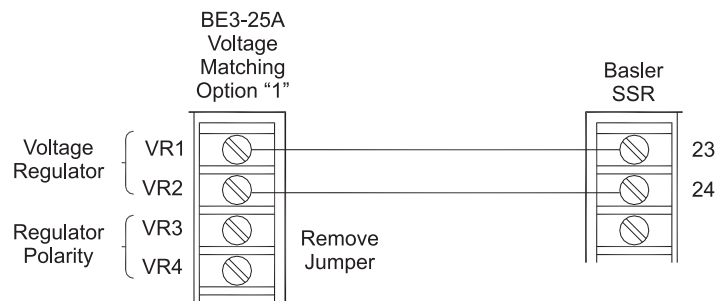

Figure 13 - Basler SSR Interconnection

INTERCONNECTIONS, continued

Power and Sensing Connections — All Options

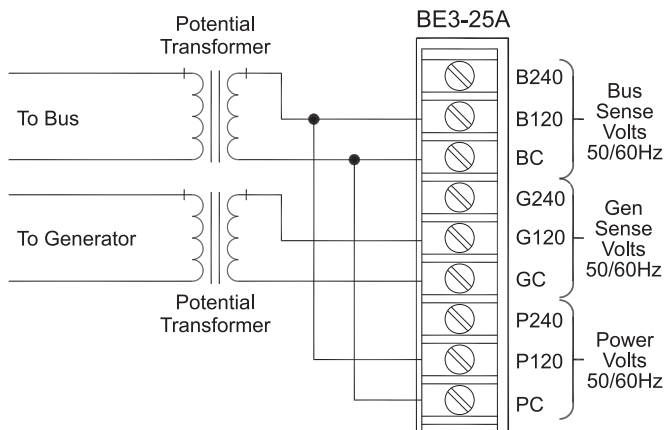

Figure 14 - 120 VAC, Power from Bus

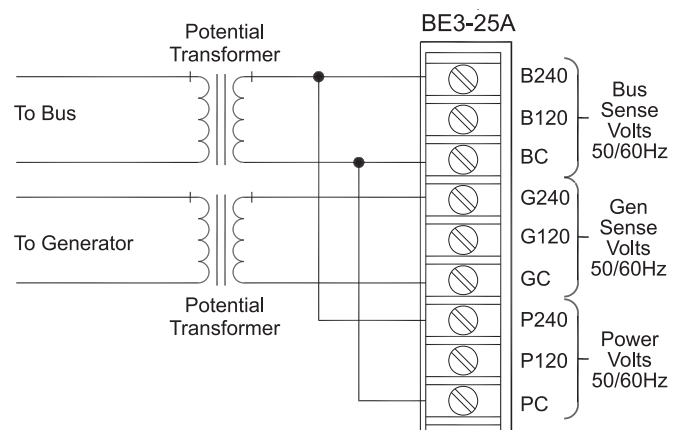

Figure 15 - 240 VAC, Power from Bus

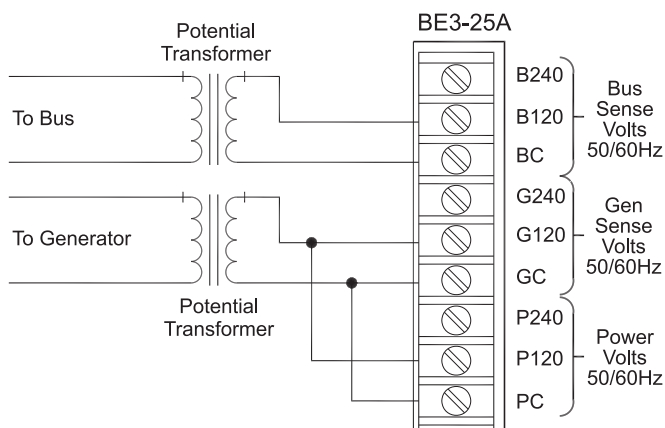

Figure 16 - 120 VAC, Power from Generator

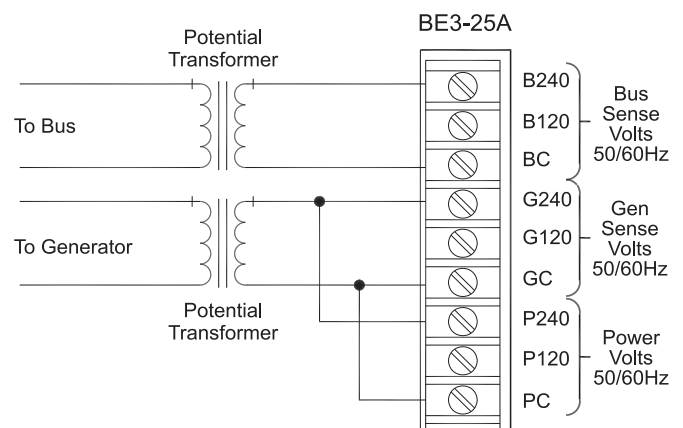

Figure 17 - 240 VAC, Power from Generator

NOTE: The potential transformer is required only if the bus/generator voltage is other than that required by the BE3-25A for sensing and input power (i.e.: 120 or 240 Vac).

ORDERING

HOW TO ORDER

Designate the model number followed by the style number.

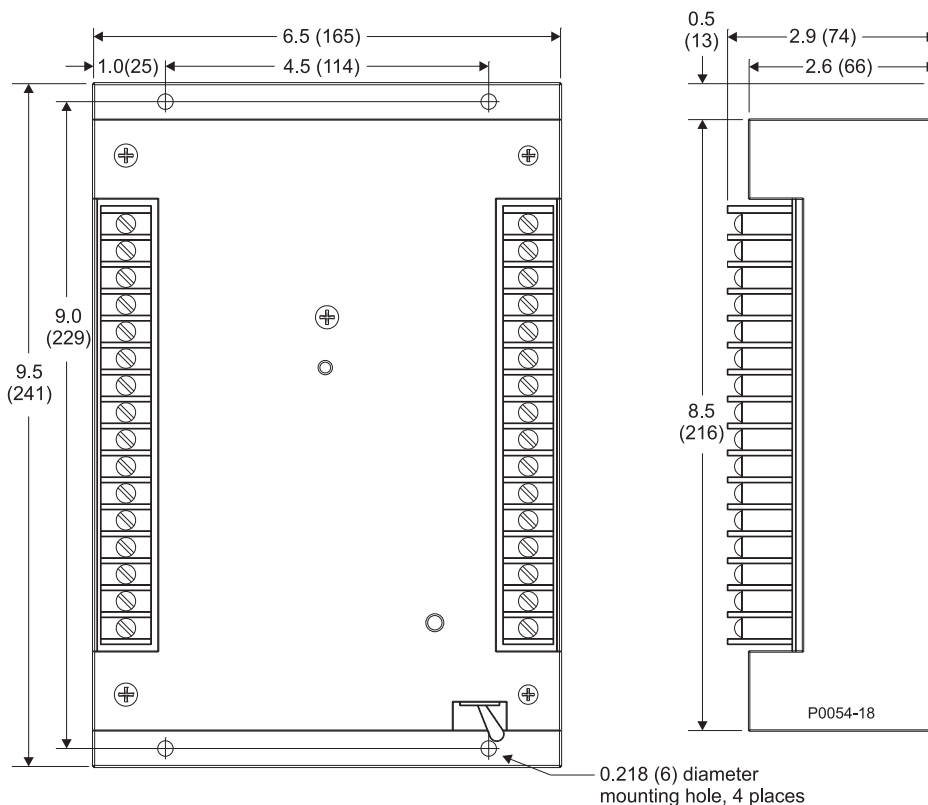
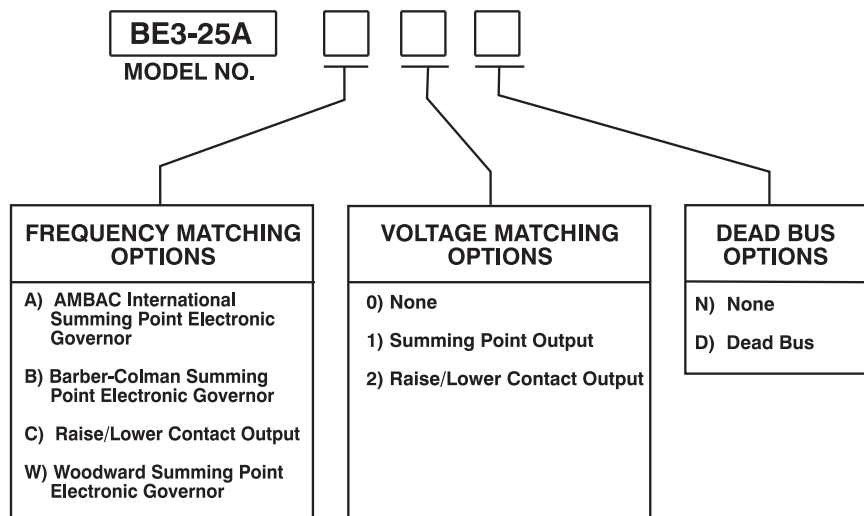

Figure 18 - Outline Drawing

Note: Dimensions in parentheses are expressed in millimeters.



ISO 9001-2008/2000
Highland, IL USA Wuzhou, France
Teylou, TX USA Suzhou, China



P.A.E. Les Pins, 67319 Wasselonne Cedex FRANCE
Tel +33 3.88.87.1010 Fax +33 3.88.87.0808
e-mail: beifrance@basler.com

Route 143, Box 269, Highland, Illinois U.S.A. 62249
Tel +1 618.654.2341 Fax +1 618.654.2351
e-mail: info@basler.com

No. 59 Heshun Road Loufeng District (N),
Suzhou Industrial Park, 215122, Suzhou, P.R.China
Tel +86(0)512 6346 1730 Fax +86(0)512 8227 2888
e-mail: beichina@basler.com